

N/A	N/A	6V150209	KIT, SEAL, FKM	N/A	NOTED
N/A	N/A	46000011	KIT, SEAL, STANDARD	NOTED	N/A
9	1	39T55002	GASKET, (-021)	X	X
8	1	81530901	RETAINER, SC, 1100		
7	1	47510900	PLUNGER, SC, 4.9 kN		
6	1	39053001	WIPER, SNAP-IN, (5/8)	X	X
5	1	39010020	SEAL, BEVEL W/HEEL INSERT, 5/8 x 1/8 x 7/8	X	39V10020
4	1	39010018	SEAL, CROWN, 11/16x7/8x5/32	X	39V10018
3	1	39000019	O-RING, (-003)	X	39051006
2	1	23600011	BALL, STEEL, ALLOY, .187	X	X
1	1	21500009	SCREW, CAP, BTNH, M10 X 16, ALY		
No.	QTY	PART No.	DESCRIPTION	Standard Seal Kit	FKM Seal Kit

Assemble with lip side facing bottom of body

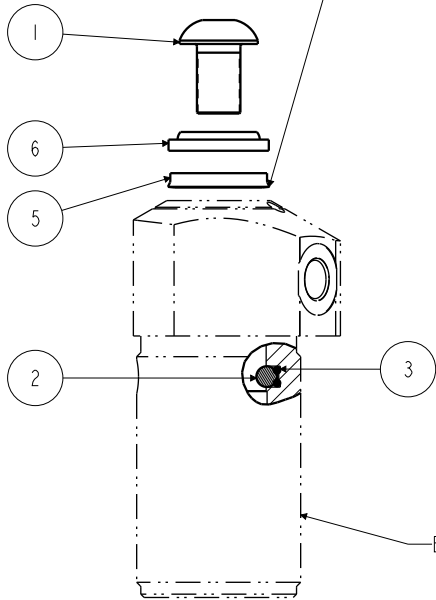

Lubricate all seals with clean hydraulic fluid prior to assembly.
Do Not Use Silicone Based Lubricants.



Body - Not Replaceable

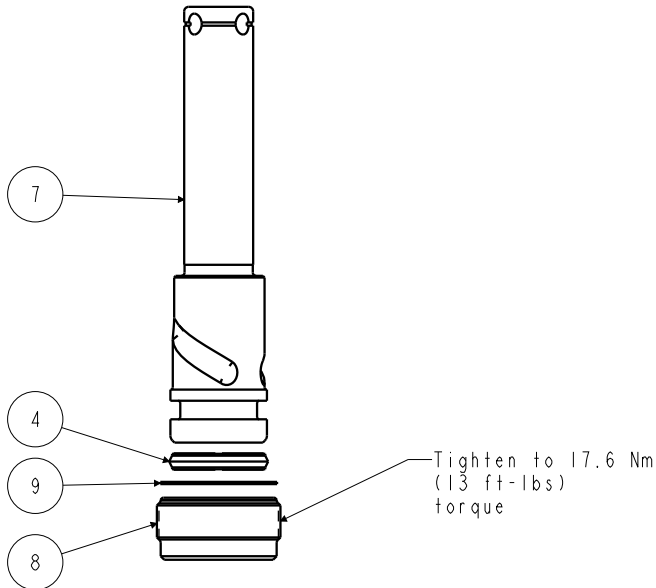

Tighten to 17.6 Nm
(13 ft-lbs)
torque

PARTS LIST



VEKTEK, INC.
1334 E. SIXTH AVE. P.O. BOX 625
EMPORIA, KS. 66801 U.S.A.

ASSEMBLIES AFFECTED

41500521
41500522
41500525

PARTS LIST, ASSY, SC, TB, 4.9KN, DA, Ver saCam

SIZE
A

MPL1503

REV
J

J	3915	RELEASE	JDW	09/13/19
REV	IN ACCORDANCE WITH ECN	EFFECTIVE DATE	REVISED BY	DATE
DRW BY: BUSH	DRAWING STATUS: Released			
DATE: 12/13/94	PRODUCTION APPROVED FOR RELEASED STATUS ONLY			

FORM FEG035_PL_ASIZE, REV. B

SHEET 1 OF 1